

# Stacked Walls – Main Components

Modular wall component diagram – standard wall panel, rail, and bracing plate.



## Standard Wall Panel

2' WIDE X 9'9"H  
MATERIAL: .090"THK 5052 AL  
WEIGHT: 32 LBS

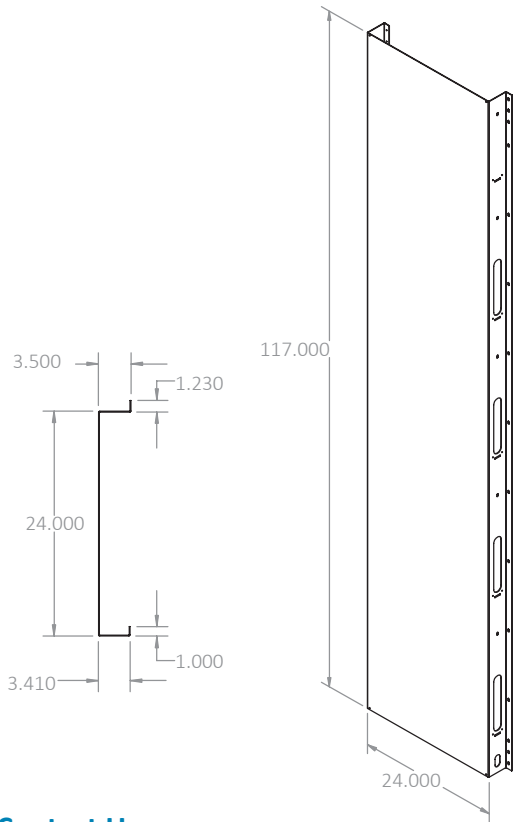

## Rail

MATERIAL: .090"THK 5052 AL  
WEIGHT: 9 LBS

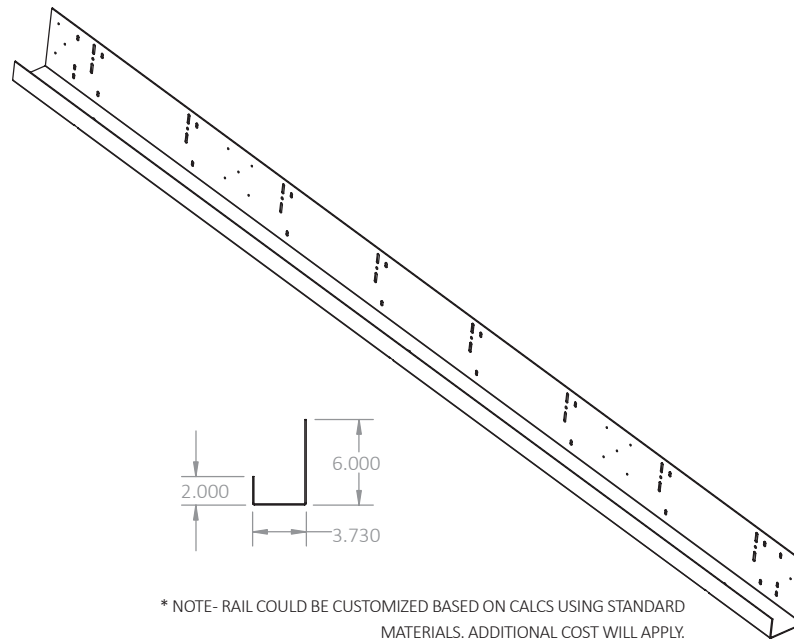

## Bracing Plate

MATERIAL: .090"THK 5052 AL  
WEIGHT: .5 LBS

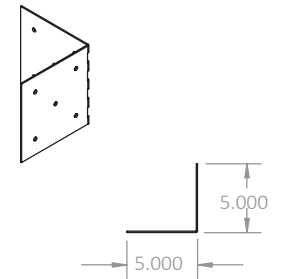

## Contact Us

For a quote, to place an order, or learn more give us a call at (760) 295-9230 or visit [www.mccainwalls.com](http://www.mccainwalls.com)

\*Dimensions are rounded to the nearest inch.

2633 PROGRESS STREET | VISTA, CALIFORNIA 92081 | USA | [WWW.MCCAINWALLS.COM](http://WWW.MCCAINWALLS.COM)

© 2018 McCain Manufacturing, Inc. Updated 11/09/18. Proudly Made in the USA by McCain Manufacturing. McCain Manufacturing reserves the right to change product specifications without notice. For the most-up-to-date information, contact us. Patent No: 10,072,411.

# Stacked Walls Configuration Sample

This view shows a sample configuration of a stacked wall utilizing the stacking brackets and rail mounts.

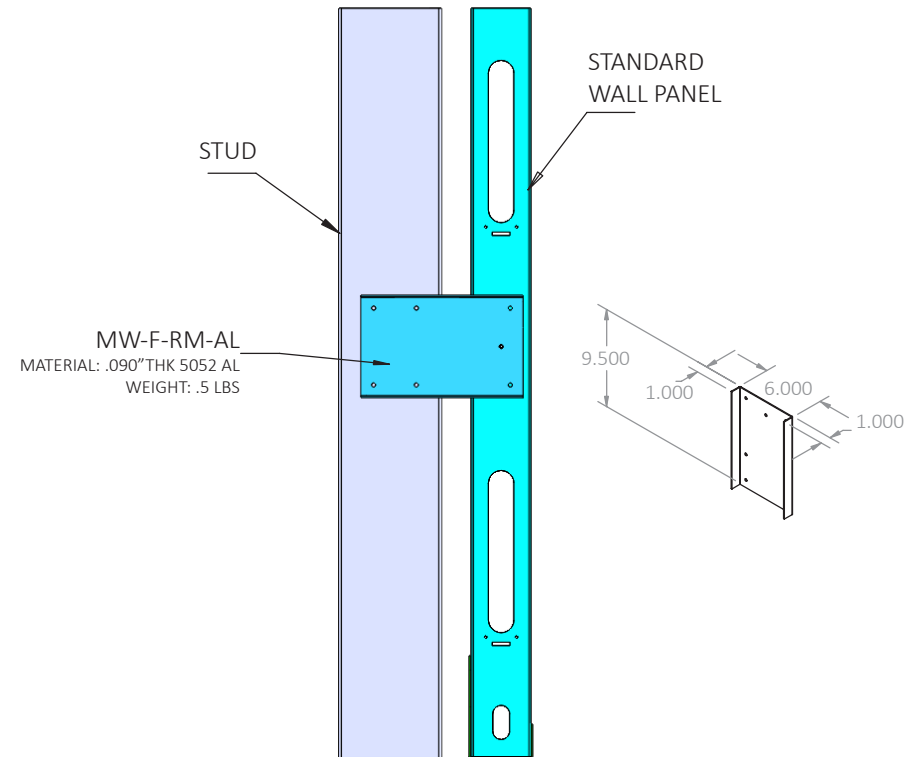
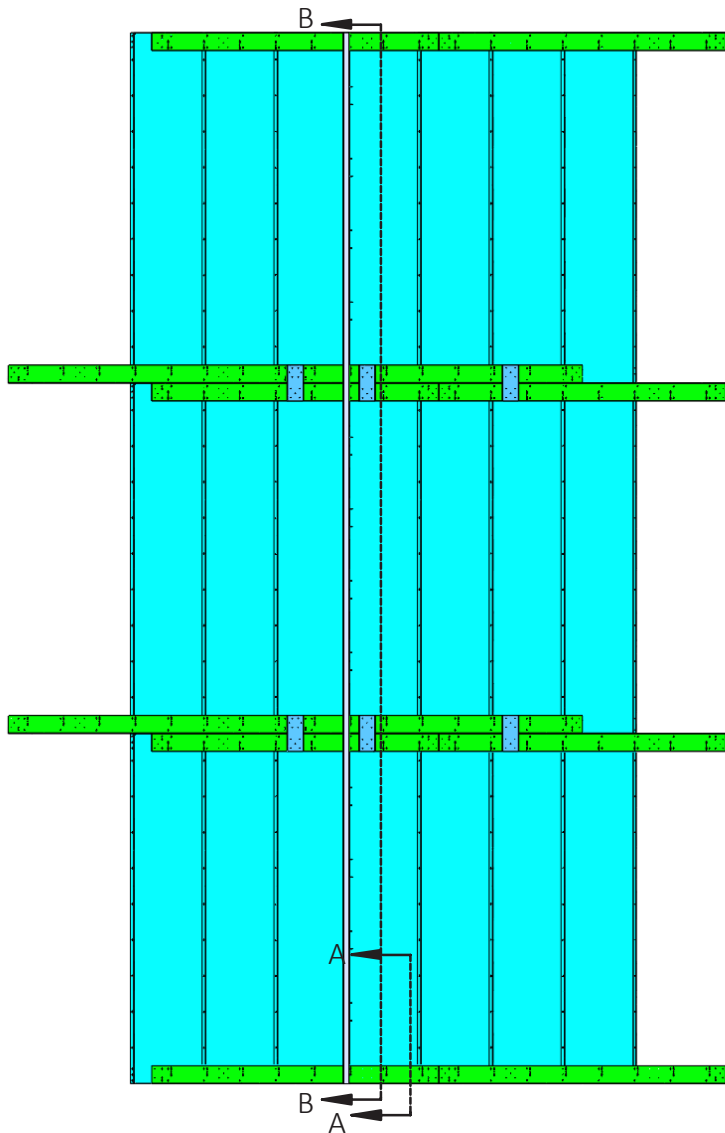

# McCain Walls® Stacked Walls Brackets



This view is intended to show the application of the stacking brackets.

